



Knight's Armament Company
7750 9th Street S.W.
Vero Beach, FL 32968

Phone: (561) 562-5697
Fax: (561) 569-2955

Commercial Installation Instructions

for the

Knight's Armament Company
Rail Adapter System (RAS)
M5 RAS for Rifle & M4 RAS for Carbine

Additional copies of these instructions may be obtained from
Knight's Armament Company

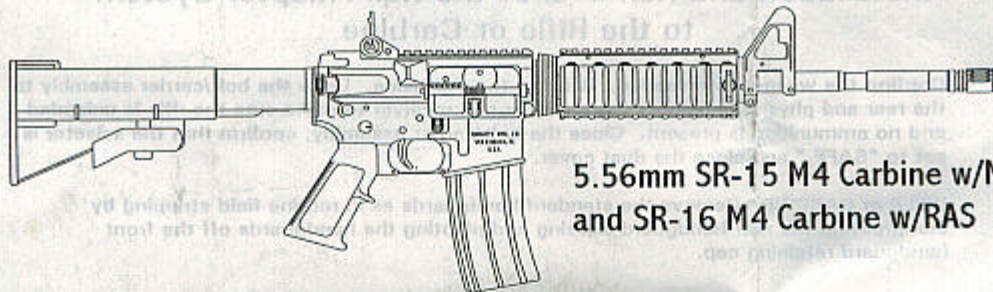

5.56mm SR-15 M4 Carbine w/M4RAS
and SR-16 M4 Carbine w/RAS

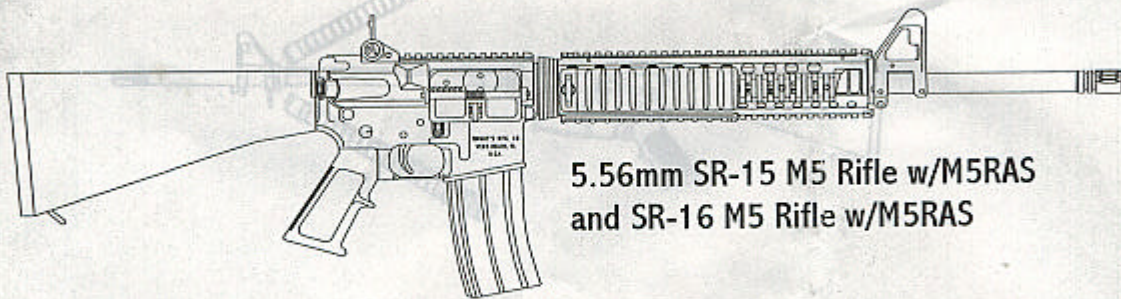

5.56mm SR-15 M5 Rifle w/M5RAS
and SR-16 M5 Rifle w/M5RAS

M5 Rifle Rail Adapter System (RAS)

Rear Locking Bracket Screw
10-32 x 3/16-inch Hex Head
P/N: 97147

M5 Rifle RAS Upper Assy.

M5 Rifle RAS Lower Assy.

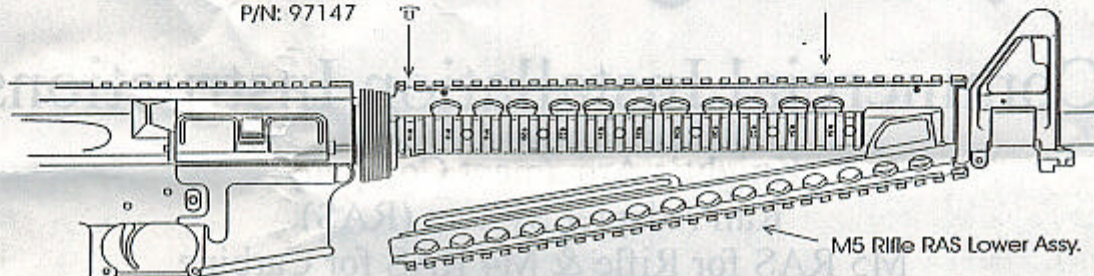

Installation and Removal of the Rail Adapter System to the Rifle or Carbine

1. **Confirm the weapon is unloaded.** Remove the magazine. Draw the bolt/carrier assembly to the rear and physically inspect the chamber and receiver to make sure the rifle is unloaded and no ammunition is present. Close the bolt/carrier assembly, confirm that the selector is set to "SAFE," and close the dust cover.
2. **RIFLE or CARBINE.** Remove the standard handguards as in routine field stripping by compressing the rear handguard slip ring and pivoting the handguards off the front handguard retaining cap.

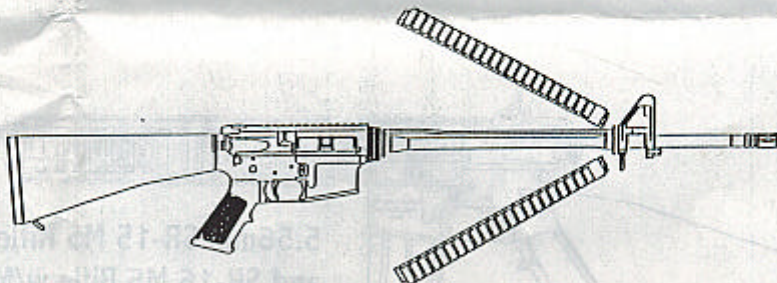

3. **RIFLE or CARBINE.** With a 1/8-inch hex wrench, remove the rear locking bracket screw. Orient the Upper RAS so the rear locking clamp is hanging down after confirming that the arrow on its inner surface points towards the muzzle of the host weapon. Insert the front end of the Upper RAS into the forward handguard cap at the angle show below. Be sure the leaf spring at the front of the RAS fits inside the lip of the handguard cap.

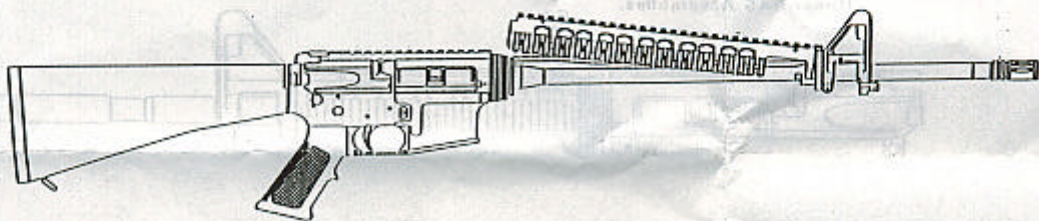

4. Continue installing the Upper RAS assembly in the same manner as a standard upper handguard by compressing the rear handguard slip ring to the rear and pivoting the Upper RAS assembly down into position. Ensure that the rear clamp's gas tube slot is straddling the gas tube and that the rear legs of the clamp slip under the barrel nut flange as the RAS makes contact with the top of the barrel nut.

Rear Clamp must hang down, and its Rear Legs must slip under Barrel Nut.



NOTE: Bracket Screw must be removed to install Upper RAS Assembly.

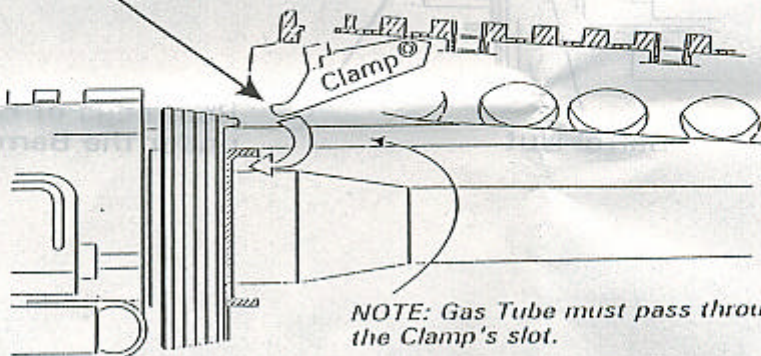

NOTE: Gas Tube must pass through the Clamp's slot.

5. Release the rear handguard slip ring and confirm that it slides forward evenly around the rear flange of the Upper RAS assembly. (Note that two alignment pins automatically interface with cut-outs in the barrel nut at the 10 and 2 o'clock positions to remove rotational play of the RAS. This helps to retain the zero of accessories mounted on the rails.) Install and lightly tighten the rear clamp's locking screw to 20-inch pounds. **DO NOT OVER-TIGHTEN THE SCREW.** The screw has a patch of thread sealant to keep it from loosening. Do not over-tighten the screw past the point of initial "metal to metal" contact. If using an Allen Wrench, do not use the long arm for tightening, but insert the long arm into the screw hex and use the short arm for tightening. If the long arm is used for tightening, you may damage the RAS or the screw. Do not exceed 20-inch pounds of torque under any circumstances, or damage to equipment may result.

Locking Screw Installation procedures are the same for both the RIFLE and CARBINE Upper RAS Assemblies.

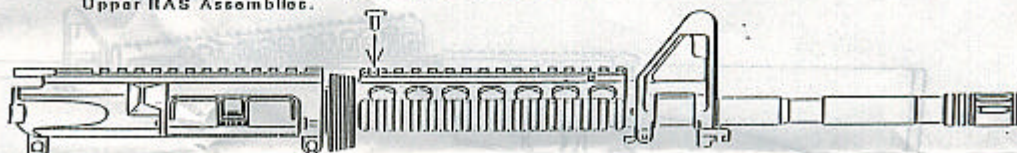

Install Rear Clamp Locking Screw.
Tighten screw to 20-inch pounds.

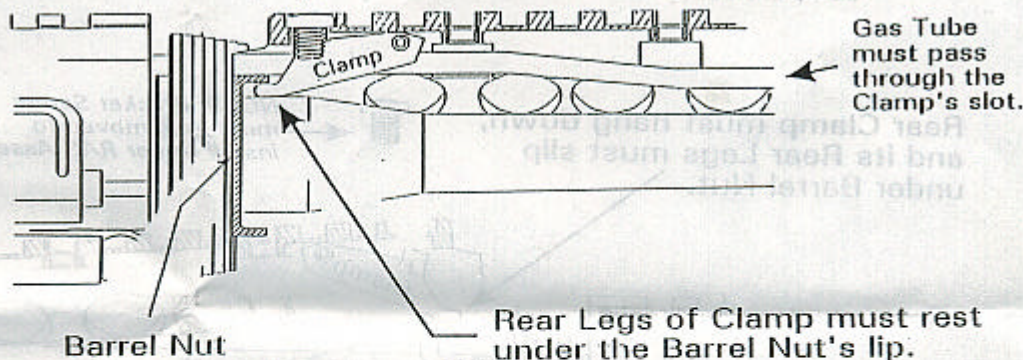

6. **RIFLE or CARBINE.** Do not remove the thermal liner from the Lower RAS assembly. Orient the Lower RAS assembly by confirming that the arrow on its inner surface points towards the muzzle of the weapon.
7. Install the lower RAS assembly in the same manner as a standard lower handguard by inserting its front edges into the forward handguard cap at the angle shown below, and compressing the rear handguard slip ring while pivoting the Lower RAS assembly up and into its final position.

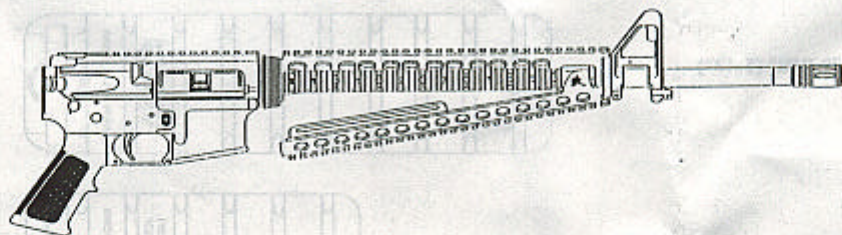

8. Release the rear handguard slip ring and confirm that it engages around the rear flange of the Lower RAS assembly.
9. The RAS may be removed by reversing the steps outlined above.

RAS HANDGUARD SECTIONS

Handguard sections are quickly attached and detached from the RAS. A spring latch at one end of each handguard section automatically engages cutouts positioned at either end of the four rail sections. To slide a handguard section beyond a cutout, or to remove it, slide it in the desired direction while applying thumb pressure to the center of its spring latch.

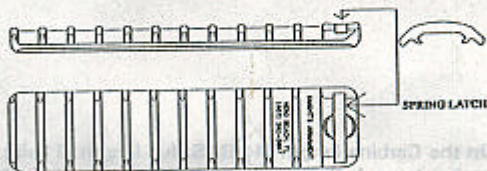

To cover the side and bottom quadrants, install the handguard sections from the muzzle end of the RAS.

To cover the top rail quadrant install the handguard sections from the rear of the upper receiver group.

As the spring latch meets its cutouts at either end of the rails, it will engage the cutouts. Shorter handguard sections used on rails partially occupied by accessories should be oriented with their spring latches away from the accessories.

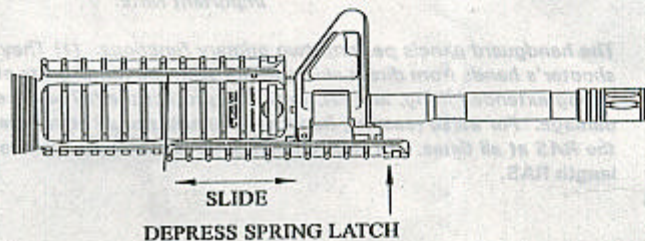

**FULL LENGTH
"11 RIB" (6.15")**



"9 RIB" (5.48")

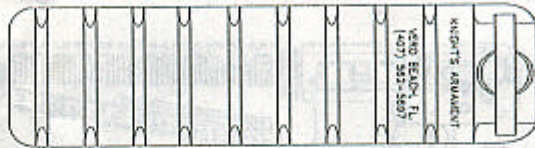

"5 RIB" (3.47")

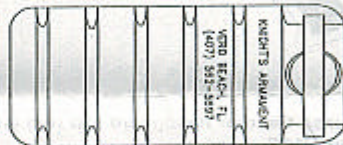

**MEDIUM SHORT LENGTH
"4 RIB" (2.65")**

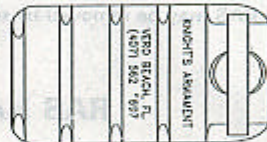

On the Carbine length M4 RAS, full length (11-rib) handguard panels should be installed with the spring latches towards the muzzle latched in grooves L28, R28, and B28. On the Rifle length M5 RAS, full length (11-rib) handguard sections should be installed with the spring latches towards the rear where they latch into grooves L14, R14, and B14. Forward mounted panels on the Rifle length M5 RAS should be latched in L or R 37 on the sides, and B42 on the bottom rail. Shorter handguard panels (used on rails partially occupied by accessories) should be oriented with their spring latches away from the accessories.

Several different lengths of handguard panels can be provided for the RAS. For ease of reference, they should be referred to by the number of ribs along their outer surfaces, i.e., 11-rib (the longest available), 9-rib, 6-rib, 5-rib, 4-rib, and 2-rib (do not count the latch area when counting ribs). Handguard panels for the RAS are illustrated above.

Important Note:

The handguard panels perform two primary functions. (1) They are configured to protect the shooter's hands from direct skin contact with the metal parts of the RAS which may get hot during extended firing, and (2), they also protect the rail surfaces from excess wear and damage. For these reasons, handguard panels should cover the unused sections of each rail of the RAS at all times. All Handguard Panels are interchangeable between Rifle and Carbine length RAS.